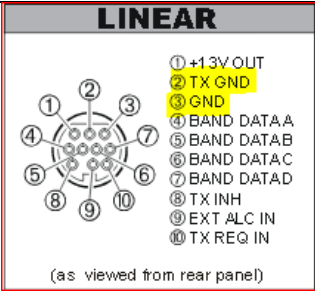

## Yaesu FTdx1200 with KPA/KAT500 Power Combo

The Yaesu FTdx1200 series radio can be connected to the KAT/KPA500 combo using the Key signal available on the rear panel of the linear and tuner. On these Yaesu radios, the keying signal is called, EX GND. This will set the KPA/KAT500 combo up for what is called, Basic Mode operation. Here's that connection found on the Linear port of these radios:

Model	Connector pin out	Menu settings to check
<b>Ft-950</b> <b>FTdx1200</b> <b>FT-450D</b>		<ul style="list-style-type: none"> <li>• Be sure to disable internal tuner.</li> </ul>

### Connections to the KPA500 and KAT500

Then, you will make the following connections with the KPA500 and the KAT500. Please note that cable items #2 and #4 are included in the boxes with the KPA500 and KAT500. We have RF patch cables available (cable #1) if needed. An adapter cable from these rigs to the KAT500 (cable #3) will be available soon from Elecraft.

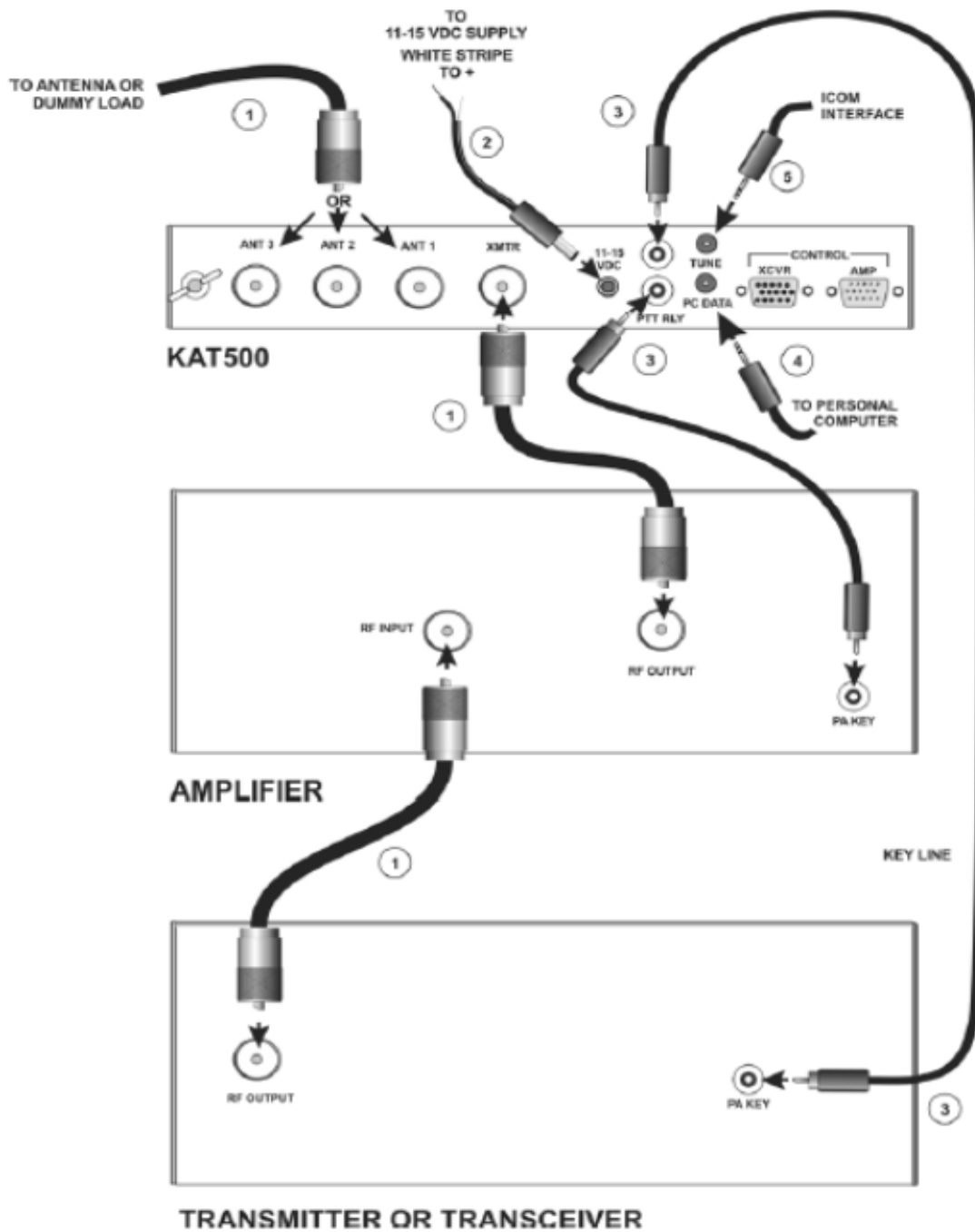

**Figure 1. General Cabling Requirements – Transmitter and Amplifier.**

Note: Cable #5 is a special connection for the KAT500 to operate as an Icom remote tuner. It is not relevant for a Yaesu radio.



## Set-Up Procedure for the KPX/KAT500 Combo

Set up the KAT500 to interoperate with the KPA500. Please enter the KAT500 Utility and select the Configuration tab then click on the button to Optimize for KPA500.

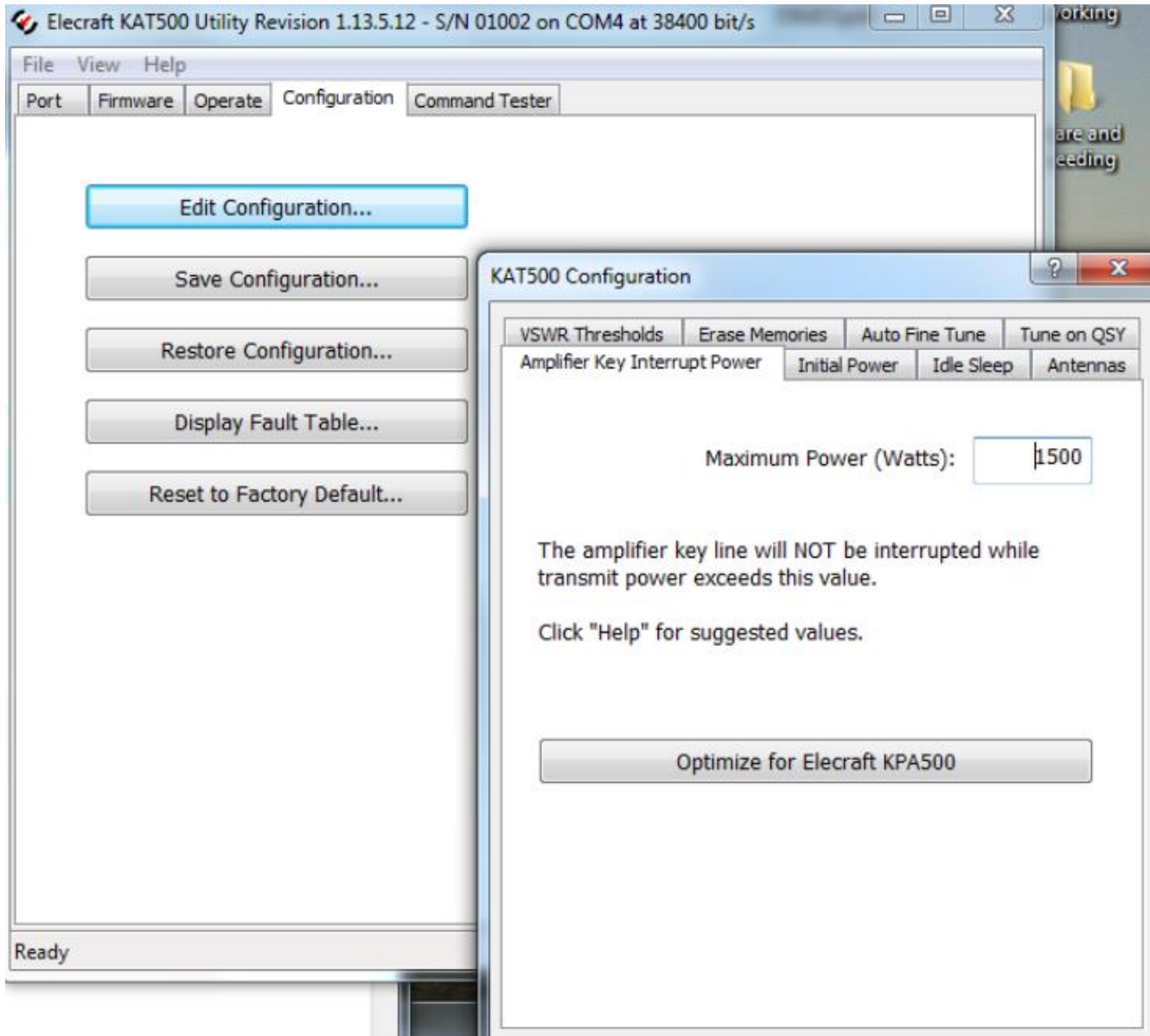



## Training the Tuner

### Overview

We will be stepping through each band where you have an antenna connected to the KAT500, selecting the top, bottom and places in the middle of each band where you expect to operate. At each of these points, we will be causing the radio to emit a steady-state RF signal for the KAT500 to use while it executes a full tune cycle. Since the KAT500 is an Automatic Tuner, it will remember the settings it finds at each of the points in the band. This is referred to as 'Training the Tuner'.

The following sequence assumes that the radio, KAT500 and, if appropriate, the KPA500 are installed as specified in the KAT500 Owner's Manual, shown above as Figure 1. Place the KPA500 into STBY mode while we train the tuner.

### Set up

- On the radio, please select RTTY mode and an RF output level of about 25 watts.
- On the KAT500, select the MAN mode.
- On the KAT500, Tap the ANT button to select the appropriate antenna. The ANT LED will light solidly indicating the antenna port selected.
- On the radio, select the appropriate band. Then, adjust VFO A to the lowest spot in that band where your antenna will work.
- We suggest you start with 160 meters and step through the bands up to 6 meters.

### For each VFO Setting perform the following to Train the KAT500:

1. Tap the MODE button so that MAN light is selected and is not flashing.
2. Next, Tap the TUNE button on the KAT500. The MAN light will now start to Flash. This indicates that the KAT500 is now awaiting the RF needed to execute a Full Tune Cycle.
3. On the radio, key the rig with the PTT button on your mic to cause the radio to go into transmit. The radio's TX light should come on to confirm it is transmitting.
4. While holding the PTT button in, the KAT500 will begin to clatter as it searches for a low SWR. This is called the Full Tune Cycle.
5. The clattering will stop once a low SWR is found and the KAT500 MAN light will now be solid. This indicates that the full tune cycle is complete and the results have been memorized.
  - a. Note that the tuner may not find a 1:1 SWR, which is normal. As long as the MAN light goes out, it has found a low SWR and has memorized the tune elements needed.
6. On the radio, adjust VFO A frequency for the upper end of the band where your antenna will operate. Repeat Steps 1-3 above for this setting.
7. Then, move into the middle of the band and repeat Steps 1-3 again.



8. These settings should give you now have stored the tuning elements needed for those band ends and middle.
9. You may go through and add more tuning memories by selecting other portions of the bands where you tend to operate frequently.

### **Train the tuner on all Bands**

- Next, step to other bands where your antenna can operate within a 10:1 SWR ratio. Perform the same steps above as with the first band chosen.
- How do you know how many times per band needed to fully train the tuner? Here's the answer from the KAT500 Owner's Manual.

### **Training the tuner with all of your antennas**

If you have more than one antenna, continue to ANT 2 and ANT 3 ports using the same technique above for those antennas. The KAT500 tuner can remember settings for all 3 antenna ports separately!

### **Make it Easy for Your Tuner to Remember what it was Trained to Do**

Once you have fully trained your KAT500 tuner on all bands and all Antennas, you can save your work using the KAT500 Utility. Go to the Configuration tab in the Utility and select Save Configuration to complete your tuner's training.

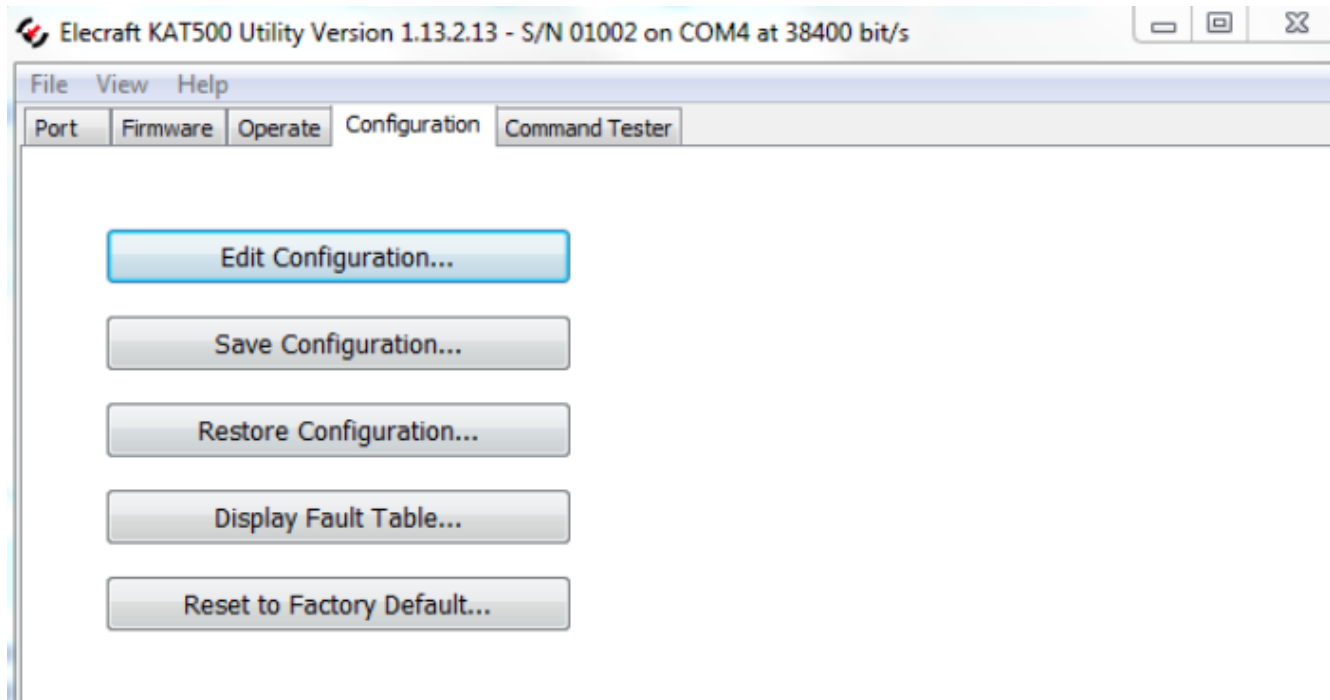

## MAN mode or AUTO mode?

Unless you intend to operate the KAT500 in a remote configuration where it may be a long distance from where you will Control it, Elecraft recommends using MAN (Manual) mode.

AUTO mode has an additional feature where the tuner will monitor SWR while you are transmitting. If, for some reason, the SWR rises above about 1.8:1 threshold (the default), AUTO mode will cause the KAT500 to enter Full Cycle Tune mode without you starting it. When used remotely, this is a very effective way of accommodating wide-ranging SWR due to weather or other conditions. Successful Full Cycle Tunes in AUTO mode will be memorized just as they are in MAN mode.

AUTO mode thresholds can be set by the operator, too. Use the KAT500 Utility to enter the Configuration dialog and select Thresholds. There you can specify, by each ANT port, what level of upper and lower thresholds you want the AUTO mode feature to monitor.

MAN mode will store successful Full Cycle Tunes just as AUTO mode will and the KAT500 will monitor SWR while you are transmitting. However, the KAT500 will not act if the SWR rises or falls. You can monitor it for yourself directly from the front of the KAT500 or from the KAT500 Utility.