

## High Power Bundle for the Flex 6500

The Flex 6500 can be connected to the KAT/KPA500 combo using the Key signal available on the rear panel of the rig. You would configure the appropriate TX port to key Here's that connection:

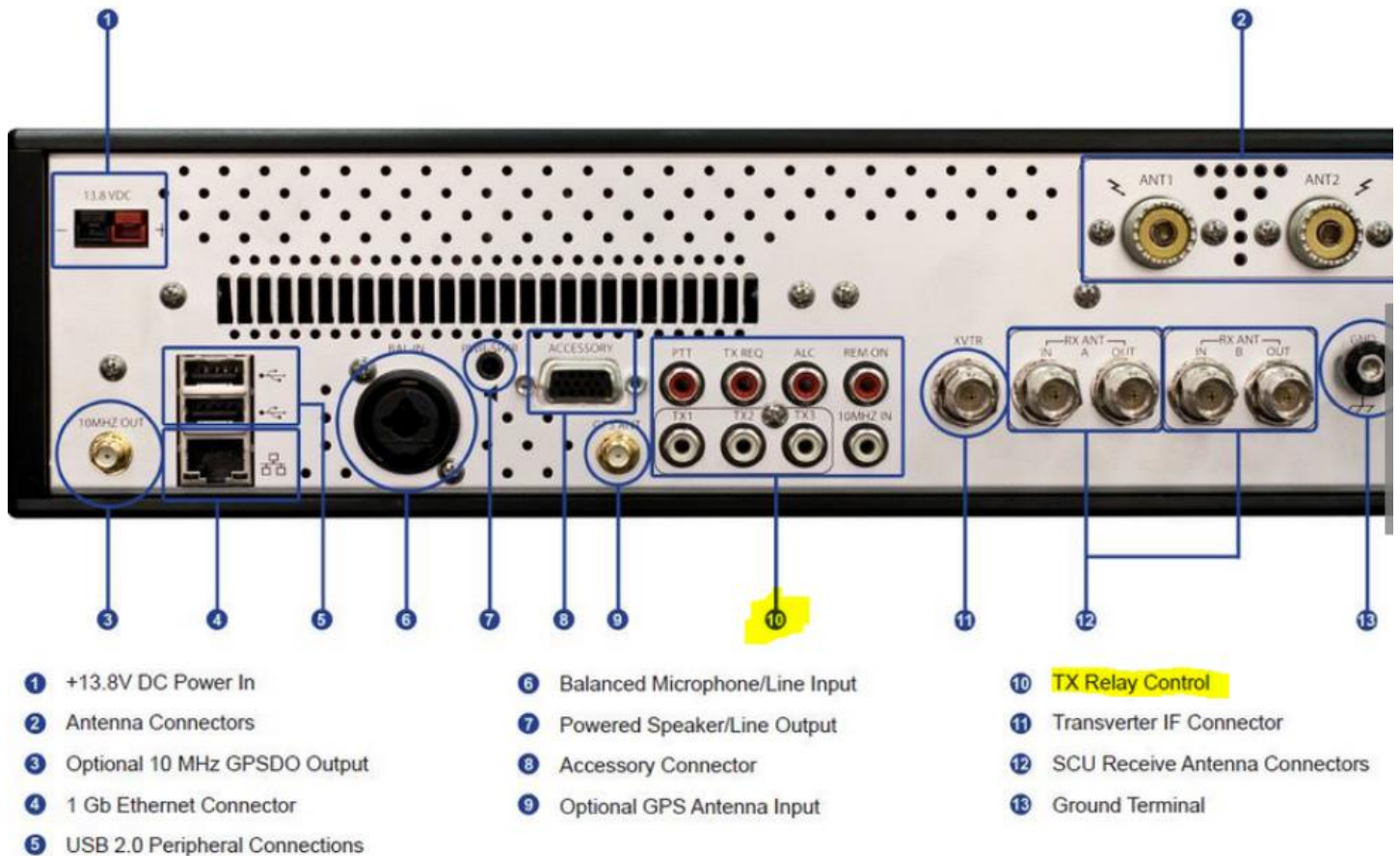

Then, you will make the following connections with the KPA500 and the KAT500. Please note that cable items #2, #3 and #4 are included. We have RF patch cables available (cable #1) if needed.

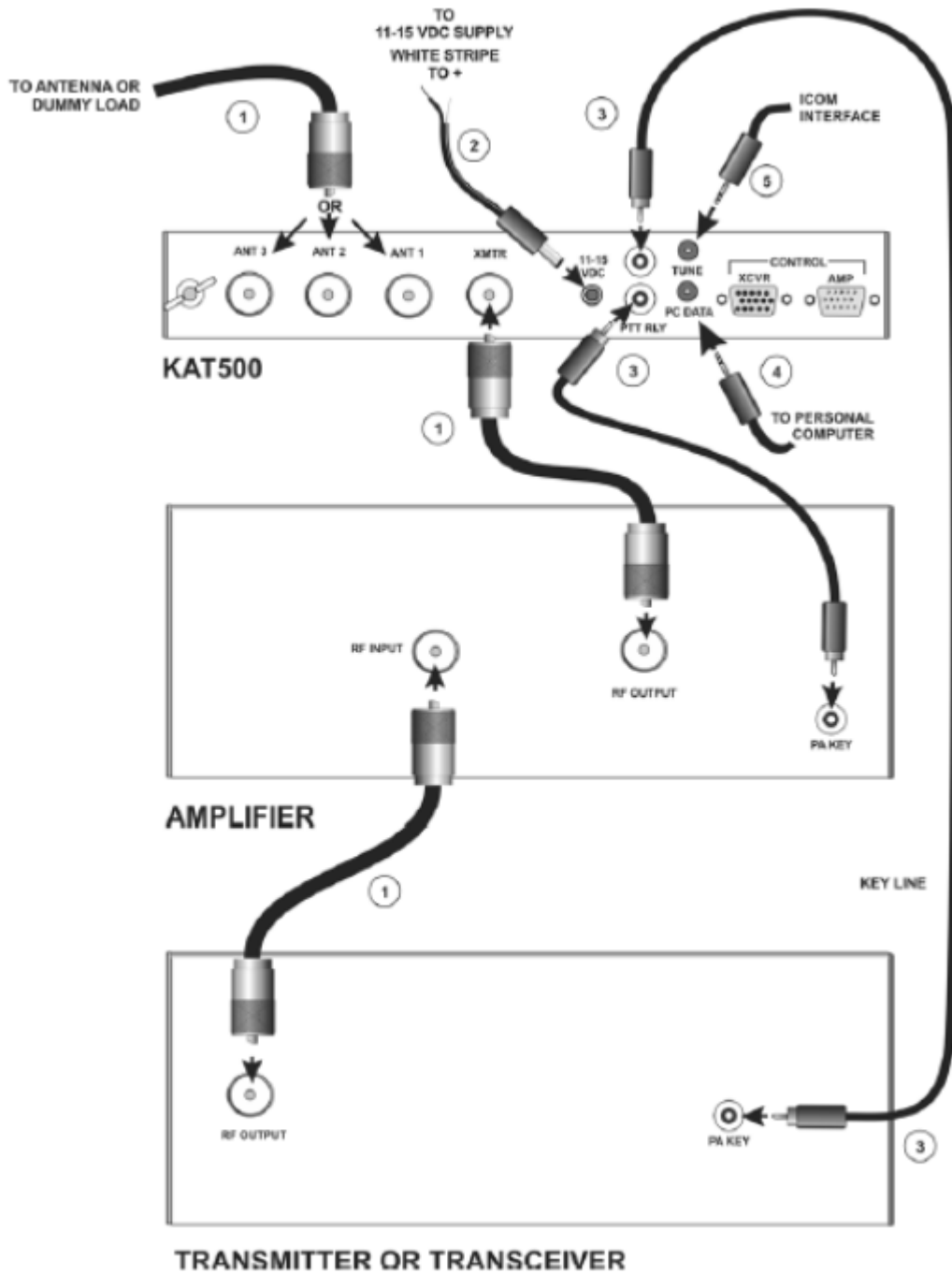

Figure 1. General Cabling Requirements – Transmitter and Amplifier.

Note: Cable item #5 is a special connection for the KAT500 to operate as an Icom remote tuner with that line of radios. It is not relevant for a Flex radio, however.

\*\*\*\*\* Here's a set Up Procedure for the KPX/KAT500

combo \*\*\*\*\*

Set up the KAT500 to interoperate with the KPA500. Please enter the KAT500 Utility and select the Configuration tab then click on the button to Optimize for KPA500.

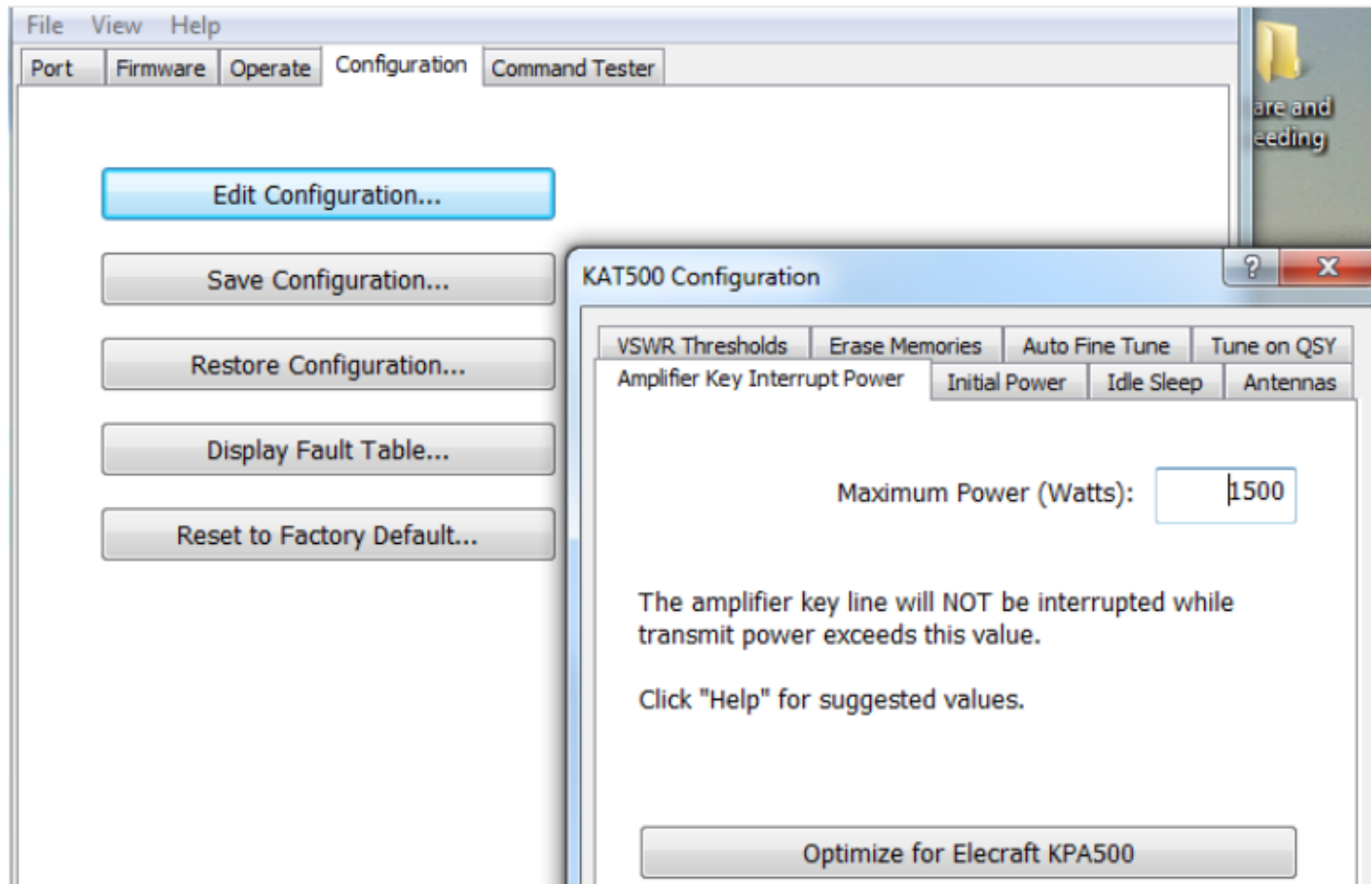

## Training the Tuner

### Overview

We will be stepping through each band where you have an antenna connected to the KAT500, selecting the top, bottom and places in the middle of each band where you expect to operate. At each of these points, we will be causing the K3 to emit a steady-state, CW RF signal for the KAT500 to use while it executes a full tune cycle. Since the KAT500 is an Automatic Tuner, it will remember the settings it finds at each of the points in the band. This is referred to as 'Training the Tuner'.

The following sequence assumes that the K3, KAT500 and, if appropriate, the KPA500 are installed as



specified in the KAT500 Owner's Manual, Figure 1.

### Set up

- On the K3, go to CONFIG: TUN PWR: set to 25 watts
- On the KAT500, select the MAN mode.
- On the KAT500, Tap the ANT button to select the appropriate antenna for the selected band. The ANT LED will light solidly indicating the antenna port selected.
- On the K3, select the the appropriate band with the Band UP/DN button. Then, adjust VFO A to the lowest spot in that band where your antenna will work.

### For each VFO Setting perform the following to Train the KAT500:

- 1) Tap the MODE button so that AUTO is enabled. The AUTO LED will stay on solidly. This places the tuner into Automatic mode so that it will remember the settings found during the upcoming tune cycle.
  - Next, Tap the TUNE button on the KAT500. The AUTO LED will now start to Flash. This indicates that the KAT500 is now awaiting the RF needed to execute a full tune cycle.
- 2) On the K3, HOLD the XMIT button to enter TUNE mode. The K3's TX LED will come on and the VFO A window will indicate the SWR while the VFO B window will indicate power, which should be close to 25W.
- 3) The KAT500 will begin to clatter as it searches for a low SWR. This is the Full Tune Cycle. The clattering will stop once a low SWR is found and the KAT500 AUTO LED will now be solid. This indicates that the full tune cycle is complete and the results have been memorized.
  - On the K3, adjust VFO A frequency for the upper end of the band where your antenna will operate. Repeat Steps 1-3 above for this setting.
  - Then, move into the middle of the band and repeat Steps 1-3 again.

### Train the tuner on all Bands

- Next, step to other bands where your antenna can operate within a 10:1 SWR ratio. Perform the same steps above as with the first band chosen.
- How do you know how many times per band needed to fully train the tuner? Here's the answer from the KAT500 Owner's Manual.



### Training the tuner with all of your antennas

If you have more than one antenna, continue to ANT 2 and ANT 3 ports using the same technique above for those antennas. The KAT500 tuner can remember settings for all 3 antenna ports separately!

### Make it easy for your Tuner to remember what it was trained to do

Once you have fully trained your KAT500 tuner on all bands and all Antennas, you can save your work using the KAT500 Utility. Go to the Configuration tab in the Utility and select Save Configuration to complete your tuner's training.

