



EVENT PLANNING TABLETOP

(TYPE 1)



Santa Clara County ARES®/RACES
Updated 05/23/2024

ARES® and Amateur Radio Emergency Service are registered servicemarks of the American Radio Relay League Incorporated and are used by permission.

HOUSEKEEPING

- Introductions
- Pen/pencil & paper
- Cell phones
- Side conversations
- Questions
- Breaks
- Restrooms
- Class Exercises
- In case of emergency
- No wandering or exploring other areas of the building

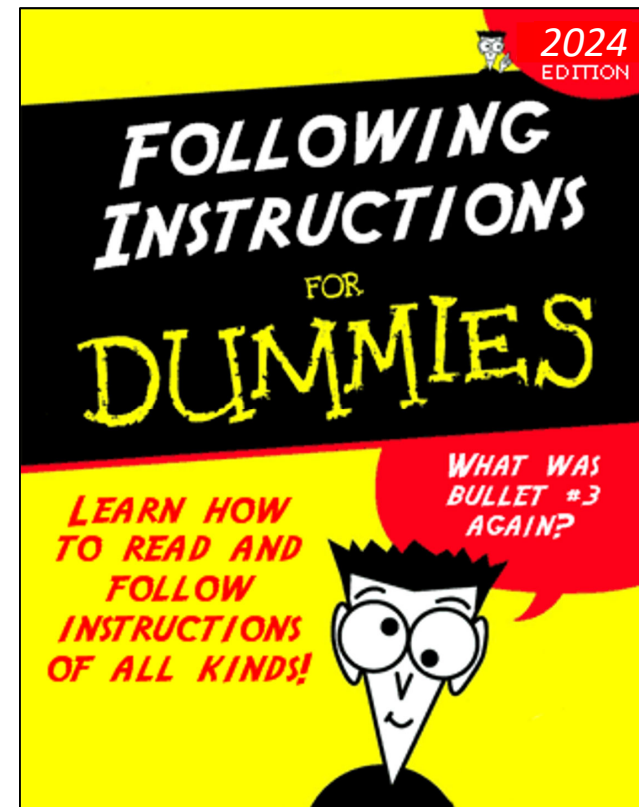

LEARNING OBJECTIVES

- At the end of this course, students will be able to:
 - Describe the different types of events
 - Create measurable exercise objectives
 - Describe the planning process and what is different based on the event type
 - Describe how to deal with problems that might be encountered during the planning process
 - Properly complete an ICS-202 Incident Objectives form
 - Explain how to use check lists as a planning aid
 - Create an event plan for a functional area of a drill or public service event
 - Create an After Action Report (AAR)

AGENDA

- Types of Planning Situations
- Event Specific Considerations
- The Planning Process
- Tabletop Exercise - *ICS-202 Incident Objectives*
- Problems and Pitfalls
- Common Planning Considerations
- Checklist as a Planning Aid
- Tabletop Exercise – *The Planning Meeting*
- Individual Exercise - *After Action Report*



We deal with many different kinds of situations, incidents, exercises, drills, activations, event, etc.

For the purposes of this presentation we will use the terms “**Exercise**”, “**Event**”, “**Drill**”, or “**Incident**” interchangeably for all of these planning situations.

TYPES OF PLANNING SITUATIONS



Drills, Exercises, and Training Events



Public Service Events



Incidents



Drills, Exercises, and Training Events

Multi-agency interoperability full scale exercise

County-Wide Comms Drill – full scale exercise

CERT support - full scale exercise

Fox Hunts – functional and full scale exercises

Interoperability functional exercise

County Quarterly Drill – functional exercise

Hospital exercises

Table top exercises

Workshops

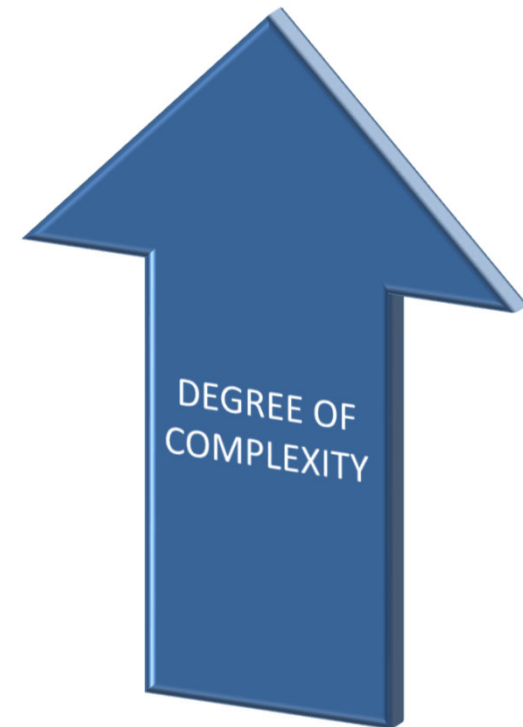



Drills, Exercises, and Training Events

Usually a fixed operational period

Can have long lead time for planning

Interact with City or County governmental agencies or entities

Can involve the entire event communications with multi-combinations of communications methods and resources or just a few of these

- Net Control
- Field Operations
- Packet Operations
- Shadowing Operations

- Amateur Radio
- Commercial Radios
- Public Safety Radios
- Others



Public Service Events

Outdoor venues – Sporting Events, Concerts

Marathons, Bicycle Rides/Races, Walks

Parades

Public Fireworks Displays, Golf Tournaments

Art and Wine Festivals

Commencement Ceremonies

Preparedness Fairs

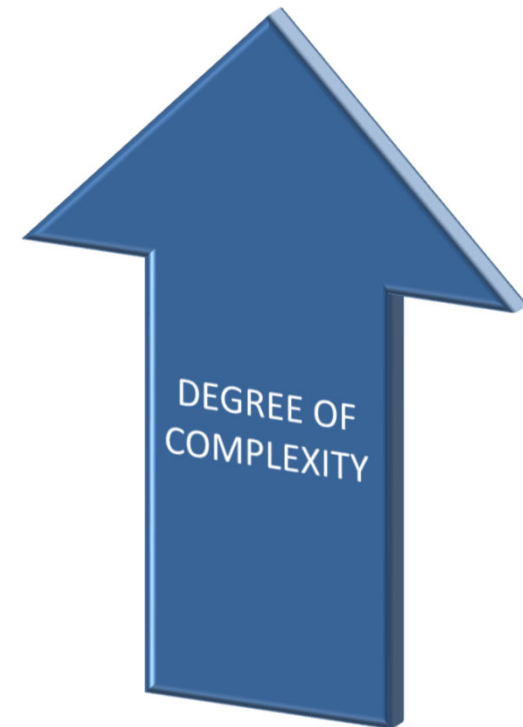



Public Service Events

Usually fixed operational period with long lead time for planning

Interact with City or County governmental agencies

- PD, CERT, Fire, Red Cross, Salvation Army, Public and Private Partners

Can be a small area of responsibility or encompass overall event communications

Attend the lead organization's planning meetings

Multiple communications systems or pathways

- Organizers, Public Works, PD, EMS, Public Health

Can involve multiple types of communications devices

- Amateur Radio (voice and/or Packet), Business radios, Phones – Sat and Landline, VOIP, GPS Tracking devices, Encrypted and Trunked Radios, ...



Incidents

Infrastructure Failures

- Technology, Utilities, Transportation

Evacuations

- Earthquakes, Flooding, Terrorist Threats, Fire, Industrial Incidents

Response and Recovery

- Warming and Cooling centers, Shelters, Points of Distribution, Points of Dispensing

Epidemics

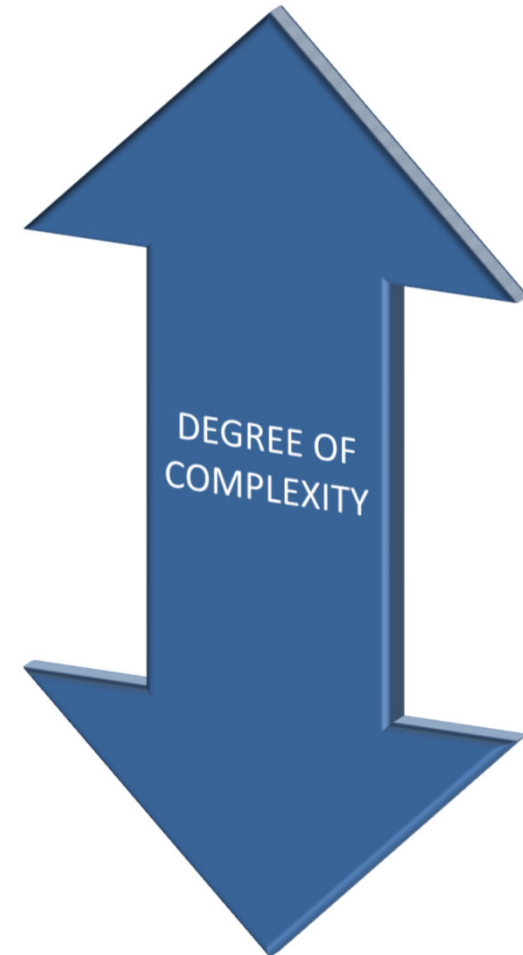



Incidents

Little to no advanced knowledge

Has no fixed operational period

- May need to plan for several operational periods each having a different set of requirements, plans, and staffing requirements
 - Event + 1 hour
 - 1 - 12 hours
 - 12 - 72 hours
 - 72 + hours



Involve Multiple Public Safety Disciplines



Incidents

May use any and all available volunteer resources for communications

Can involve mixing volunteer communication resource types

May involve the use of non-hams ACS (Auxiliary Communications Service volunteers)

May involve the use of SUVs (spontaneous unaffiliated volunteers)



PLANNING

“Why should I develop a plan? It’s just one more thing to go wrong.”

“If you fail to plan, you are planning to fail”

What is a plan?

- **A plan defines the means to achieve a set of goals and objectives.**

What is planning?

- **Planning is the process by which a plan is formulated and documented.**

How detailed does a plan need to be?

- **Must contain sufficient detail that the staff knows what must be done but still follow the KISS principle.**

THE PLANNING PROCESS

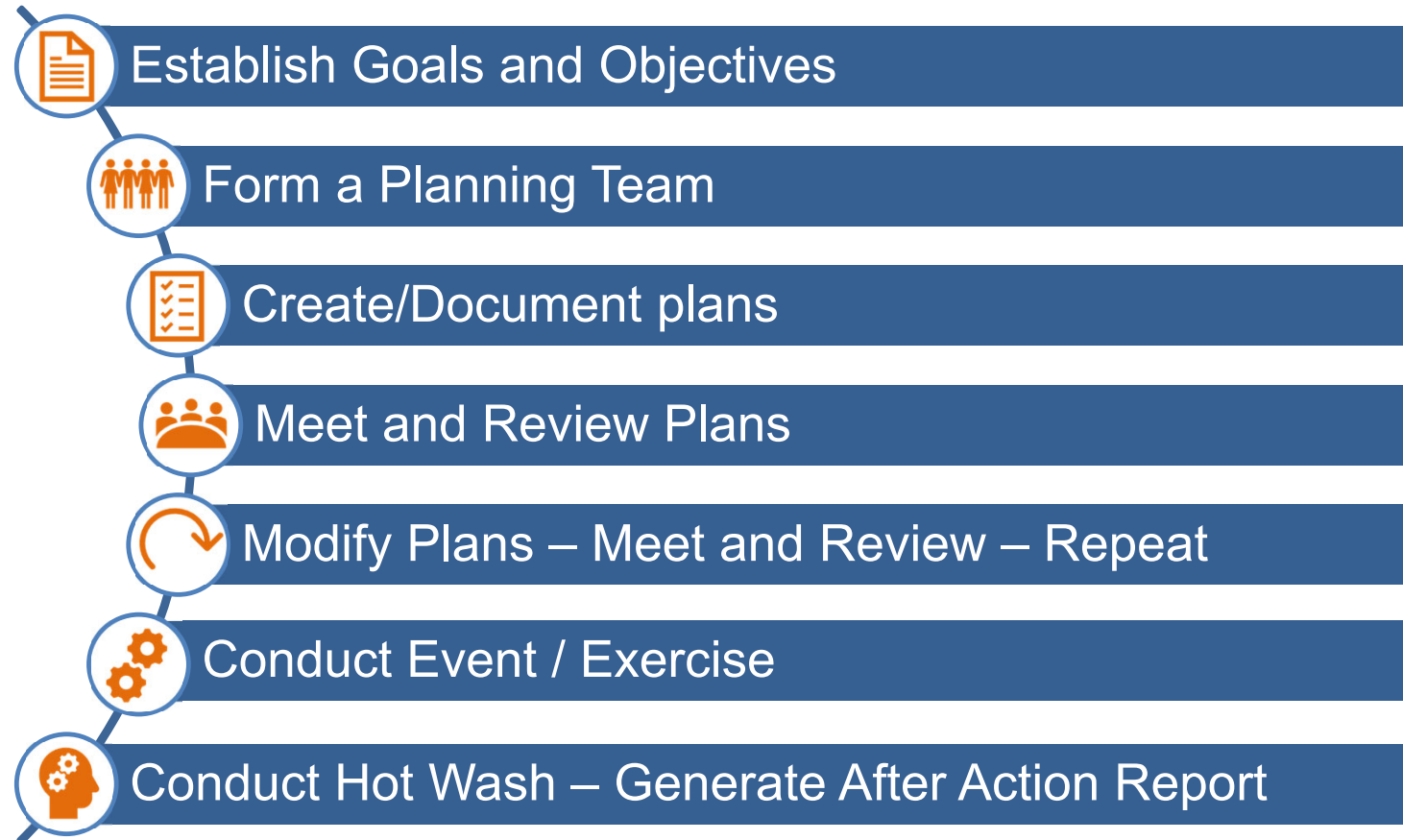



Establish Goals and Objectives



Difference between Goals and Objectives

- Goals relate to your aspirations, where do you want to be.
- Objectives are your road map, how do you get there.
- Limit the number of exercise objectives to enable timely exercise conduct.

GOALS	OBJECTIVES
Broad statements	Detailed statements
Abstract	Specific and concrete
Intangible	Tangible
Difficult to measure	Measurable



Establish Goals and Objectives

Planners should create objectives that are **SMART***

S	M	A	R	T
Simple Specific	Measurable	Attainable	Realistic	Task Oriented Time Bound

Don't try to cover too broad an area

Can it be determined if the objective was achieved?

The objective should not be too difficult to achieve

The objective should present a realistic expectation

The objective should be task oriented/time bound

The objective should focus on a behavior or procedure

* Ref. FEMA IS-120A, *An Introduction to Exercises* Course

Copyright 2024 Santa Clara County ARES®/RACES. All rights reserved.

DOCUMENT GOALS & OBJECTIVES

We use an ICS-202 Incident Objectives form

ICS 202 INCIDENT OBJECTIVES SCCo RACES		1. INCIDENT NAME	2. DATE	3. TIME
4. OPERATIONAL PERIOD			5. MISSION NUMBER XSC -	
6. GENERAL CONTROL OBJECTIVE FOR THE INCIDENT (Include alternatives)				
7. WEATHER FORECAST FOR PERIOD				
8. GENERAL SAFETY MESSAGE				
9. ATTACHMENTS (mark if attached)				
<input type="checkbox"/> ICS 204 Assignment List (comms)		<input type="checkbox"/> ICS 201 Incident Briefing (RACES)		
<input type="checkbox"/> ICS 211A Check In List		<input type="checkbox"/> ICS 205 RACES Radio Communications Plan		
<input type="checkbox"/> ICS 214 Unit Log		<input type="checkbox"/> Other _____		
10. ADDITIONAL REMARKS				
ICS 202 SCCo RACES		11. PREPARED BY (planning section)	12. APPROVED BY (incident commander)	

ICS-202 INCIDENT OBJECTIVES

ICS 202 INCIDENT OBJECTIVES XND RACES	1. INCIDENT NAME Xandau Fire Works Event	2. DATE 05/04/19	3. TIME 1000
4. OPERATIONAL PERIOD 07/04/2019 1600-2300		5. MISSION NUMBER XND-19-06T	
6. GENERAL CONTROL OBJECTIVE FOR THE INCIDENT (include alternatives)			
7. WEATHER FORECAST FOR PERIOD			

ICS-202 INCIDENT OBJECTIVES

8. GENERAL SAFETY MESSAGE

This activity will take place at Central Park. It is expected there will be over 25,000 spectators in attendance and over 200 city staff and volunteers.

All participants must follow XND Performance Standards. Maintain hydration and use sunscreen. Have flashlights for nighttime work. Slight chance of light wind by 2130 so a light jacket may be needed.

9. ATTACHMENTS (mark if attached)

- | | |
|---|---|
| <ul style="list-style-type: none"> <input type="checkbox"/> ICS 204 Assignment List (comms) <input type="checkbox"/> ICS 211A Check <u>In</u> List <input type="checkbox"/> ICS 214 Unit Log | <ul style="list-style-type: none"> <input checked="" type="checkbox"/> ICS 201 Incident Briefing (RACES) <input checked="" type="checkbox"/> ICS 205 RACES Radio Communications Plan <input checked="" type="checkbox"/> Other: 2019 XND Fireworks Op Plan |
|---|---|

10. ADDITIONAL REMARKS

ICS 202 XND RACES	11. PREPARED BY (planning section)	12. APPROVED BY (incident commander)
------------------------------	---	---

ICS-202 INCIDENT OBJECTIVES

Are these SMART Objectives?

- Send all ICS-213 message forms with 100% accuracy within 3 minutes or less per form.
- Complete all required forms with 96% accuracy by end of shift.
- Meet communication needs of served agency during the operational period to satisfaction of the Incident Commander.
- Net control will conduct H&W checks of all staff every 30 minutes and promptly notify IC of anyone missing.
- Provide all first-time participants with 30 minutes of Packet experience with a mentor sending and receiving ICS-213 forms.
- Notify Medical staff of all aid requests within 2 minutes of receipt.

TABLETOP GROUP ACTIVITY

Establish a Planning Leader: they are responsible for coordinating your team's efforts. It is suggested it should be someone with experience working events of various types (Type 2 or very experienced Type 3).

Develop and document Incident Objectives for the following event.

GOAL:

- Provide communications support for the Mockingbird Heights Mummy Race which takes place from 2000 to 2400 on Halloween. Provide support for participant safety, track all participants, request any necessary medical aid when needed, provide race officials with situational awareness.
 - There are 4 checkpoints, a start and finish line, two medical locations, and 7 key race officials.

Remember you're only completing the ICS-202 Incident Objectives form at this point, you are not planning the entire event.

Your finished product will be an ICS-202.

GROUP BREAKOUT DISCUSSION

What are your objectives? Are they SMART?

What did you determine for Safety?

Other thoughts/comments/observations?





Form an Exercise Planning Team



A planning team can consist of multiple team members in the case of a complex situation such as a major exercise. It can be just one person in a less complex event or activity.

- In an activation, for the first few hours it may be just you!

For drills and exercises the planning team may or may not be responsible for conducting the exercise.

Assign task/roles for each area planner.

- Net Control, Packet, Field Ops, Shadow, Staging, Safety,

PLANNING TEAM ORG CHART

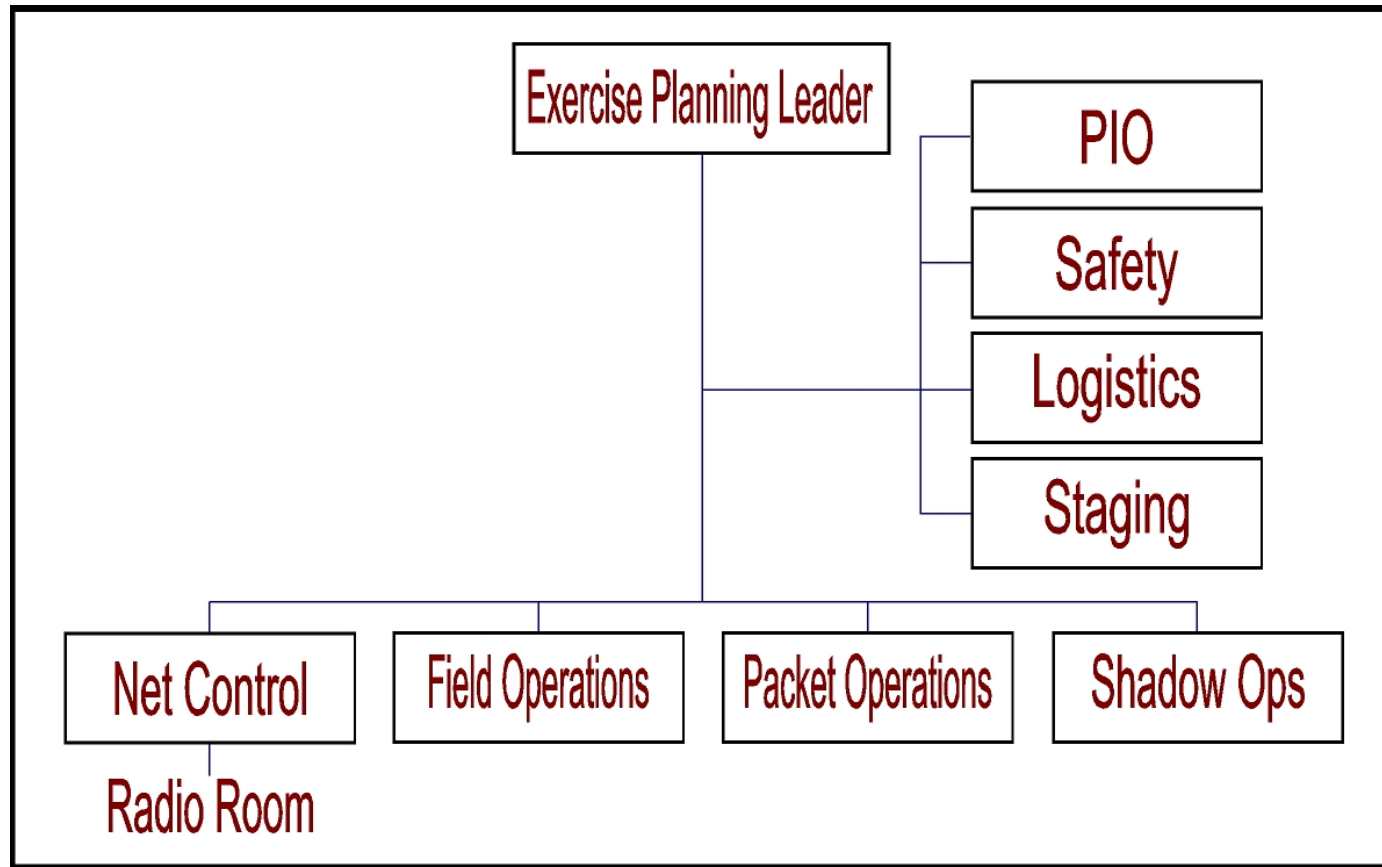

Can be modified to fit event needs

PLANNING TEAM ORG CHART

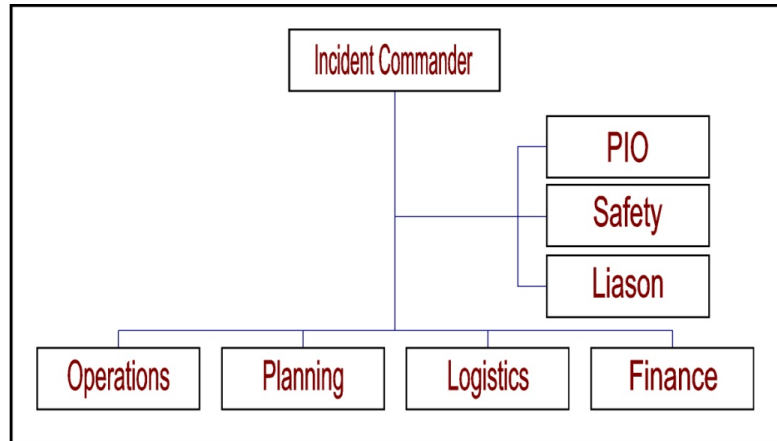

ICS Org Chart

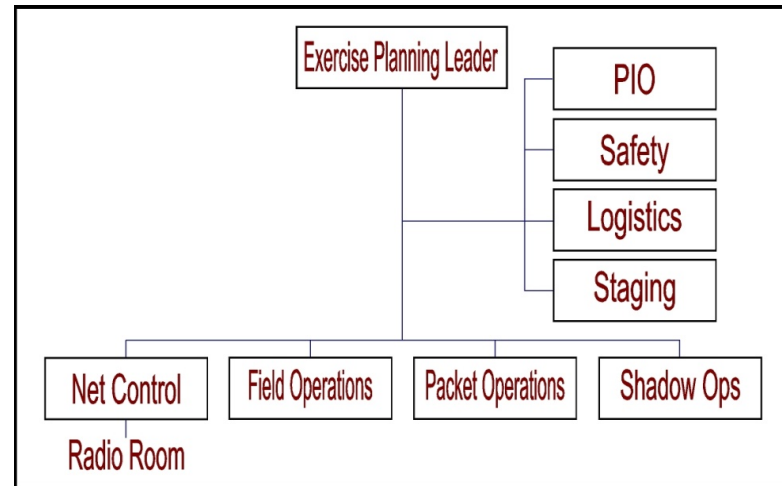

Drill Planning Org Chart

- ICS is used for real incidents
- We practice as we would operate for the real thing
- For exercises, Operations is broken out to distribute the workload and offer additional planning opportunities

PLANNING CONSIDERATIONS

Some things to think about while developing the plan

- Purpose of the event
- Goals and Objectives
- Scenario (for simulated events)
- Capabilities you can provide – don't over promise
- Expectation of served agency – get their feedback for your AAR
- Communications needs (voice, packet, shadows, etc.)
- Staff – Who, skill levels, how many
- Logistics - Materials/Equipment
- Safety Requirements/Considerations
- Participant Guidelines/Artificialities/Simulation Guidelines
- Participant Instructions/Briefing
- Hot Wash – Participants and Staff
- After Action Report





Create/Document plans



Create a written plan for each functional area of the exercise

Make sure your plan addresses the overall Goals and Objectives

Review previous plans for similar events

Review previous AARs for lessons learned

Determine and document staffing and equipment needs

All planners should coordinate their plan with other area planners

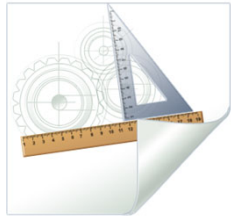

Create/Document plans



We use the following to document our plans

- ICS-202 Incident Objectives
- ICS-201 Incident Briefing
- ICS 205 Communications Plan

For the large county wide communication drills, typically:

- The Incident Commander/Planning Leader selects the planning staff
- The head of each function (Field Ops, Net Control, Shadow, Packet, Staging, Logistics, Safety, and PIO) documents the details of each area and recruits staff
- This distributes the workload; gives everyone experience



Meet and Review Plans



The planning meetings should include discussions on:

- **Assigned Roles and Responsibilities** – Ensure the exercise team members understand their roles and responsibilities and are equipped to complete them successfully.
- **Plan Coordination** – All functional areas should be involved and consulted.
- **Follow Up** - Schedule several mid-term meetings (as needed) to integrate and verify that compatibility exist between all the exercise components, timelines, and schedules.
- **Final Planning Meeting** – final review of all plans and components of the entire exercise for all planners and ALL staff members.



Conduct Exercise



Recruit Participants for Drills and Public Service Events

Set up at the exercise site

Introduce the exercise to the assembled participants.

- Distribute participant materials and hold briefings

Conduct the exercise as planned according to your timeline

Mitigate (and document) any problems that occur during the event



Conduct Hot Wash (Debrief)



An Exercise Debrief session is conducted that is open to participants, staff and evaluators to collect feedback.

Conduct an exercise debrief.

Compile all pertinent notes, observations, and hard copy documentation. These notes should include the observations voiced by exercise participants during exercise play and the debrief discussion, as well as other observations.

Have a meeting with Planning Staff to discuss the exercise

- What worked? / What needs to be changed/improved?



Generate After Action Report



AAR includes

- Description of exercise and its goals and objectives
- Results achieved
- Problems and concerns
- Observations and feedback
- Lessons learned
- Improvement ideas for future events
- Appendices & Attachments
 - Copies of all drill planning documents
 - Copies of all drill paperwork, forms, notes, etc.
 - A scenario discussion summary that includes any identified communications gaps and their respective recommendations that can be traced back to comments/observations at the exercise.

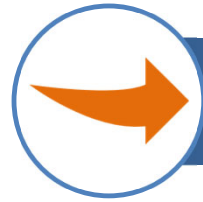

Continuous Improvement Planning



The continuous improvement process focuses on using the information documented in the AAR to implement improvements.

The lessons, observations, and insights from the AAR must be translated into actions that result in capability improvements.

An After Action Conference should be held, in which the exercise planning team, exercise implementation team (if different), and others gather to review the AAR.

Make changes to training, procedures, documentation and equipment to address any issues noted.



PROBLEMS AND PITFALLS

(AKA: THINGS TO KEEP IN MIND)

PROBLEMS AND PITFALLS DURING EXERCISES

- **Confusion about when to ID, and how to use tactical and team calls.**
- **Decide in advance of the exercise what your tactical calls will be; they should be obvious, like “Xanadu EOC” or “Station 88”**
- **Not knowing how to program radio**
- **Not knowing how to exchange 3rd party traffic**
- **Not using phonetics, or using non-standard ITU phonetics**
- **Not using “This is drill traffic” when passing traffic during a exercise**
- **Not keeping a dedicated radio on the team’s primary frequency**
- **Not advising repeater owner or control op before commandeering a repeater**
- **Staff didn’t show up or is late**
- **Equipment malfunction**
- **Stuck Mic**
- **Weather issues**
- **Other unforeseen events / problems**

PLANNING CONSIDERATIONS COMMON TO MOST ACTIVITIES

- **Frequency Selection**
- **Fundamental Overload**
- **Intermod**
- **Antenna Placement**
- **Transmit Power Selection**
- **Physical Space, Equipment, Documentation and Staffing**

FREQUENCY SELECTION

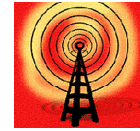

Repeater vs. Simplex

- Use simplex for events with people in close proximity
- Use repeaters when wider coverage is needed
- Repeater users can use less power than if they used simplex
- Repeaters don't work well if users are near each other – desense

Band Selection

- Use 2m and 70cm where dependent on field volunteers
- Just about any HT works on 2m; most have a dual-band HT
- Use 1.25m for packet comms when possible
- Many EOCs have 220 packet radios
- Use different bands when close proximity is required

Frequency Selection

- Space across the band if possible; perform intermod calculations
- Identify backup frequencies in advance
- You're not the only one on the air: other individuals, events, jammers

FUNDAMENTAL OVERLOAD

FOR MORE DETAIL, CONSULT THE ANTENNAS COURSE

What is fundamental overload?

- 1) The effect of a signal at the receiver input that is too strong for the receiver circuits to process properly
- 2) Overload of a radio receiver due to the strength of a transmitted signal's fundamental or intended component
 - Ham radios w/ wide filters are more susceptible than commercial radios
 - Most cases of interference are due to fundamental overload

Remedies:

- Reduce the power of the transmitter
- Separate the antennas (power is reduced by square of the distance)
- Point antenna(s) in a different direction (if not omnidirectional)
- Select a frequency that is as far away as possible from offending signal
- Select a frequency in another band
- Ferrite beads at antenna feed point
- Ferrite beads on all cables entering and leaving the radio
 - Power cable, serial cable, coax ...

INTERMODULATION DISTORTION

FOR MORE DETAIL, CONSULT THE ANTENNAS COURSE

Commonly called “intermod” or “IMD”

What is intermodulation distortion?

- Two signals combining in such a way as to create intermodulation products – signals at various combinations of the two original frequencies
- IMD can be generated inside a transmitter or receiver or externally by signals mixing together in non-linear junctions or connections (also called passive intermod or “PIM”)
 - Loose connections, rusty bolts, dissimilar metals, etc.
- May be a combination of fundamental and harmonic frequencies

Remedies:

- Avoid 3rd order intermod frequency relationships
 $2*f_1 - f_2$, $2*f_2 - f_1$, $f_1 + f_2 - f_3$,
 $f_1 - f_2 + f_3$, ...
- Reduce power
- Use directional antennas

ANTENNA PLACEMENT

FOR MORE DETAIL, CONSULT THE ANTENNAS COURSE

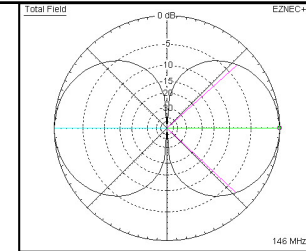

Vertical Dipole
Side View

Reduce interference with proper antenna placement

Typical vertical antenna pattern

- Most energy is directed horizontally, very little energy is directed vertically

Vertical separation is best for confined areas

- i.e. collinear, 10-20 ft vertical separation; with no horizontal offset
- Combine vertical and horizontal separation when necessary

Example (vertical $\frac{1}{2}$ wave dipole):

- 10 ft vertical separation is approx. = 50 ft horizontal (36 dB)
- 20 ft vertical separation is approx. = 225 ft horizontal (48 dB)
- Source: <http://www.repeater-builder.com/antenna/separation.html>

If possible, locate different net controls at different places

- Alleviates constraints on frequency selection, antenna placement
- Resource Net is very flexible – three repeaters to choose from

TRANSMIT POWER SELECTION

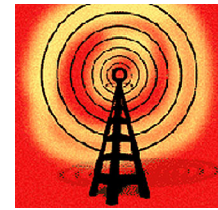

10-50 watts will de-sense anything nearby

If using repeaters

- Minimize local de-sense by minimizing power on voice channels
- Repeaters usually have very good “ears”; can hear you with less power

If using simplex

- De-sense isn't as much a problem on the same channel
- Could still cause a problem on adjacent channels

Use the minimum power required (except for packet – hidden node)

Reducing power can help with both fundamental overload and intermodulation distortion

PHYSICAL SPACE, EQUIPMENT, DOCUMENTATION, STAFFING



Tables, chairs, forms control, paper weights

Shelter from: rain, moisture on paper, wind, noise, sun light, crowds

Lighting if working after dark

What quantity and type of message traffic is expected

Schedule of operators

- Pre-scheduled or On-demand
- Limitations on number of participants at any one time

Briefing documents for participants

- Purpose/objectives of exercise
- Schedule
- How paperwork will be handled
- Any procedures specific to this event or served agency
- ICS Forms (205, 211, 213, 214, 309) - people will forget to bring

CHECKLISTS AS A PLANNING AID

USE OF CHECKLIST

- What does a checklist do?
 - It supplies a set of checks to ensure the obvious but critical stuff is not overlooked.
 - It ensures that people talk, coordinate and accept responsibility while being left the power to manage the nuances and “unpredictabilities”
 - It reminds us of the minimum necessary steps and makes them explicit.
- Why is a checklist necessary?
 - It mitigates faulty memory and distractions

TYPES OF CHECKLISTS

- ▶ Common to all areas
- ▶ Overall event planning - Incident Commander (IC)
- ▶ Net Control
- ▶ Packet
- ▶ Field Operations
- ▶ Shadow
- ▶ Logistics (materials)
- ▶ Safety
- ▶ Staging
- ▶ Public Information Officer (PIO)



Samples provided as part of class handouts



COMMON TO ALL AREAS (EXCEPT SHADOWS)

- Power requirements
 - AC power available
 - AC Power Supplies
 - Generators / Batteries
 - Power Distribution
- Tables, chairs, forms control, paper weights
- Forms, T-cards, clipboards, pens, maps
- Shelter from: rain, wind, noise, sun light, crowds
- Lighting if working after dark
- If Credential evaluations are needed or desired (Net Control, Field Ops, Packet, Shadow) work with the evaluators for those areas.



INCIDENT COMMANDER OVERALL EVENT PLANNING

- The IC is responsible for the overall event plan. He/she develops a framework for the exercise and determines the following initial planning considerations:
 - What do I want to get out of the exercise? Goals, Objectives
 - How complex do I want it to be?
 - How long will it go?
 - What do I want to evaluate/test?
 - What is the scenario?
 - Who do I need to help me plan the exercise?
 - Form a Planning Team and conducts planning meetings.
 - Simulation Cell considerations if required
 - Obtain Activation Number (6-8 weeks in advance for SCCo OEM)
 - Will Credential Evaluations be needed? Contact Evaluation Coordinator.



NET CONTROL PLANNING FOR AN EVENT

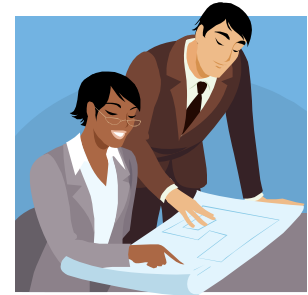

- Components of a net control plan
 - Net types / quantity
 - Frequency selection
 - Power level selection
 - Antenna placement
 - NC Operator/Scribe Schedule
 - Personnel requirements/assignments
 - Net control scripts
 - Net control briefing
- Equipment
 - Radios, headset, footswitch, audio splitters
 - Antennas, masts, cables, coax, connectors, safety markings
 - Power – available on-site, generators, batteries, solar



NET CONTROL

NET TYPE AND QUANTITY CONSIDERATIONS

- Resource Net
 - Directed net
 - Common for county exercises and many city exercises
 - Required for activation under DSW and mutual aid
 - For smaller events, consider an informal “talk in” frequency
 - Larger nets will probably need an experienced NCO, scribe
 - If possible, arrange event so everyone doesn’t need to be travelling at the same time
 - Doing Demobilization Resource Net with an off-site operator frees staff to pack-up and depart event venue



NET CONTROL

NET TYPE AND QUANTITY CONSIDERATIONS

- Message Net / Field Team nets
 - Directed net
 - Formal traffic: shelters, schools, fire stations, ...
 - How many teams? Messages per team? Time/message? Operator quality?
 - Usually about 4-5 teams max per net based on traffic levels
 - All informal: parades, bike races, checkpoints, rovers
 - How long to gather key data (crowd size, etc.), health & welfare?
 - Usually no more than 15-20 per net
 - Mixture
 - Think through traffic types, quantity of messages per team, quantity of teams, health & welfare checks, capability of likely net control operators, availability of net control operators
 - Larger nets will need a scribe



NET CONTROL

NET TYPE AND QUANTITY CONSIDERATIONS

- Shadow Nets
 - Usually works best as an open net with a liaison instead of NCO
 - Most shadows need to talk to another shadow, not to net control
 - Traffic is almost always informal (usually no forms-based traffic)
 - Try to stay with one shadow net whenever possible
 - Shadows are highly mobile/portable
 - Radio is in pouch, backpack, vest, etc.; difficult to switch frequencies
 - HT output is mono; difficult to tell which frequency is in use
 - Working two frequencies usually only possible with 2 HTs; 2 earbuds
 - Open net performance is dependent on everyone on net
 - Consider: who the operators will be; how “chatty” the principals are; number of shadows; number of expected messages per shadow; ...
 - If you need more than one net, divide according to traffic clusters
 - Geography, functional area, etc.



NET CONTROL

NET TYPES AND QUANTITY CONSIDERATIONS

- Command Net
 - For event staff to communicate with each other
 - Large events can benefit greatly; some medium events, too
 - Typically operated as an open net (may or may not have NCO)
- Packet Nets
 - May use existing county BBS frequencies
 - May use separate training BBS and non-SCCo frequencies
 - Can greatly reduce the traffic level on message nets
 - Encourage use, especially when formal message traffic is needed
- Staging nets and other tactical nets
 - Where and when needed
 - Can be quite large, but relatively simple – check-in/out; H&W
- Create the ICS-205 Communications Plan



NET CONTROL

ICS 205 – COMMUNICATIONS PLAN

COMMUNICATIONS PLAN SCCo ARES/RACES/ACS		1. Incident Name/Location Countywide RACES/CERT Exercise, Moffett Field			2. Activation Number XSC-18-08T		3. Operational Period Date/Time From Date: 10/27/2018 To Date: 10/27/2018 From Time: 0600 To Time: 1600		
4. Communications Resources									
Ch #	Function	Call Sign and/or Sys / Net / Ch / TG Name	Assignment	Rx Freq_N / W	Rx Tone or NAC	Tx Freq_N / W or + / - / S	Tx Tone or NAC	Mode A,D,M	Remarks
	Emergency	9-1-1	All event staff and participants	Telephone		Telephone		M	For actual emergencies, first call 9-1-1. Then report the situation to Net Control, prefacing your message with "THIS IS NOT A DRILL."
	Resource	AA6BT Resource Net Primary	RACES resources traveling to or from the drill site	146.115 W		+	100.0	A	Directed Net. Link to N6NAC. Link repeaters at 0600. Unlink after finished tracking departing resources (~1600). Frequency open to non-participant use during low resource net utilization.
	Resource	W6ASH (UHF) Resource Net North	RACES resources traveling to or from the drill site	440.800 W		+	100.0	A	Link to AA6BT
	Resource	N6NAC Resource Net South	RACES resources traveling to or from the drill site	444.625 W		+	110.9	A	Linked from AA6BT

- Function – primary function
- Call Sign and/or Net – e.g. repeaters call sign, name of the net
- Assignment – brief description of how used
- Rx Freq (narrow / wide), Rx Tone, Tx Freq (N/W), Tx Tone
- Mode – Analog, Digital, Mixed
- Remarks – important comments for implementation
- Plan for backup frequencies in case of failure, jamming, overload, ...

NET CONTROL SCHEDULING CONSIDERATIONS



- Resource Net
 - Beginning of event
 - Start net from home; hand-off net to on-site operator as soon as net control station is up and running at event
 - During event
 - May run as open net; may have peak usage during shift changes
 - End of event
 - Start net from event; hand off to off-site operator as soon as possible so you can pack up and leave the event location
- Staging Net (or event tactical net)
 - Ready to go prior to arrival of first participants
 - Runs until last participant leaves
- Field nets; shadow nets
 - Ready to go prior to first assignment
 - Runs until last assignment is completed

NET CONTROL SCHEDULING CONSIDERATIONS



- Operator capability
 - Drills are an excellent time to learn, but you can frustrate people and discourage participation if the nets aren't run efficiently
 - Public service events are a chance to showcase our talents; you can create a public image problem if nets aren't run well
 - Consider pairing experienced with inexperienced for "elmering"
- Shift overlap
 - Typically plan for 30 minute overlap in shifts
 - Usually covers relief briefings, snags at staging, paperwork, etc.
- Expect things to go wrong
 - It's an unfortunate reality that not everyone will honor their commitment to be there on time (or even be there at all!)



NET CONTROL SCHEDULING CONSIDERATIONS



- For training events such as drills
 - Rotate staff on a regular basis
 - Shorter shifts can accommodate more training/eval opportunities
 - Minimum shift recommendation: 1 hr
 - Create net control schedule for the whole event, including Resource Net before and after the event
 - Make all other schedules subservient to the net control schedule
 - No one can miss their net control assignment or else all activities for that net are impacted
- Demobilization
 - Allow for possibility of event running faster/slower than expected



NET CONTROL

FINALIZING THE PLAN



- Personnel requirements/assignments
 - Net control and scribe for each shift
 - Back-up/waiting list in case of no-shows
 - Pre-assign first and last shift – pre-assign all shifts if possible.
- Net control script contents
 - Introduction, check-ins, instructions, regular announcements/ID, health and welfare, check-out/hand-off, closing
- Briefing
 - Purpose/objectives of net
 - Schedule
 - Net control script
 - How paperwork will be handled
 - Any procedures specific to this net or event or served agency



PACKET SPECIFIC FREQUENCY AND POWER LEVEL SELECTION

- Frequency Selection
 - BBS network has 144, 220, and 440 frequencies
 - 144 - most common
 - 220 - less chance of interfering with voice
 - Not heavily used by most packet users
 - Driven by most accessible BBS node
 - Have a backup frequency plan and define conditions for switching
 - There may be intermod!
 - There may be intentional interference
- Power Selection
 - You need to have a strong signal so others can hear you
 - But 25-50 watts will de-sense anything near by
 - Coordination with voice nets is needed

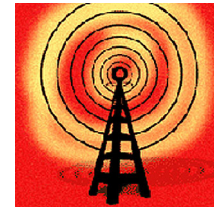

PLANNING A PACKET NET

- What type of packet communications will be needed
- Equipment
 - BBS Utilization - remote or local BBS
 - Radios
 - TNCs
 - Antennas, mast, tripod, weights
 - Coax and connectors
 - Printer for printing messages
 - Paper
 - Ink/Toner
 - Special power needs
 - Sunlight shielding
- Power requirements
 - Is AC power available
 - AC Power Supplies
 - Generators / Batteries
 - Power Distribution

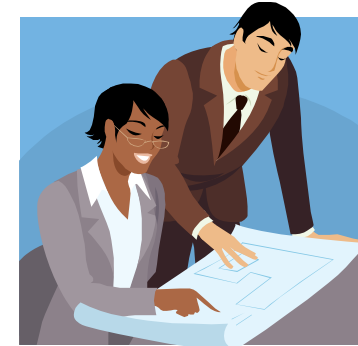

PACKET OTHER CONSIDERATIONS



- Try to balance packet message load among the BBS nodes
 - May want to add a backup node (W5XSC-1) for practice
- Have a clear understanding of the message flow between packet stations
- Have a clear understanding of the paper flow for each packet station
- Packet operators will also be on a voice net for H&W checks
 - Select a voice net and alternative for all packet operators



PACKET

OTHER CONSIDERATIONS

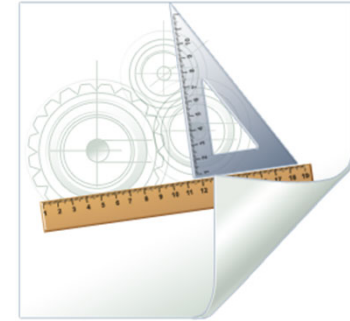

- Personnel requirements/assignments
 - Packet Operator for each shift
 - Back-up/waiting list in case of no-shows
 - Pre-assign first and last shift
- Predetermined message contents
 - Introduction, check-ins, instructions, regular announcements/ID, health and welfare, check-out/hand-off, closing
 - Event Notices (bulletins)



FIELD OPERATIONS PLANNING

- What type of field communications will be needed
 - Fixed location
 - Mobile in vehicle
 - Mobile on foot or bicycle
- How many Nets – coordinate with Net Control Planner
 - What quantity and nature of message traffic is expected
 - Messages per hour
 - Informal vs Formal messages
 - How many people assigned per net based on traffic levels
- Weather Considerations
- Equipment – provided by operators or pre-staged?
 - Radios
 - Headset, footswitch, audio splitters
 - Antennas, masts, cables, safety markings
 - Coax and connectors



FIELD OPERATIONS PLANNING

- Schedule of operators
 - Pre-scheduled
 - On demand
 - Limitations on number of participants at any one time
- Briefing documents for participants
 - Purpose/objectives of event
 - Schedule
 - Any procedures specific to this event or served agency
- Credential Evals should be coordinated with Evaluation Coordinator



SHADOW PLANNING



- What is expected shift length
- Who can use or might need a Shadow
- Determine potential traffic levels for Principals
- Determine how mobile the Principal will be (fixed vs highly mobile)
- Environment/Weather considerations
- Determine staffing needs
 - Assign Shadows to Principals based on expected traffic levels and the Shadows ability/experience/fitness
 - Shadow Equipment
 - Power requirements for shift
 - Is the demeanor/personality of shadow and principal a good match
 - Are the duties of the Principal compatible with the Shadow
(dressing rooms, medical issues, etc.)



SHADOW PLANNING

- Frequency selection – coordinate with NC and other event planners
 - Simplex or Repeater
 - Is a Crossband repeater needed
- Plans to deal with Stuck Mic or Jammers
- Publish list of Tactical Calls for all Shadows
 - (IE: Pete's Shadow, IC's Shadow, Police Liaison, etc.)
 - Include Principals name and assigned Tactical Call
- Create Briefing Document for Shadows
- Determine if Credential Evaluations will be needed/offered
 - Assign Shadows being evaluated to appropriate traffic level positions
 - Coordinate with Credential Evaluator
- Conduct briefing, answer any questions
- Plan for relief operators



LOGISTICS PLANNING

- Determine equipment needs from each planner and IC
- Develop list of what is available and who will supply it even if a planner will provide it for their own area of responsibility
- Seek out items still needed and arrange to borrow/obtain them prior to the event
- Use a Spread Sheet to document all equipment needs and who will provide each item
- Share list with IC and all planners
- Determine how to locate/provide items still needed



Logistics - Equipment - Name Of Exercise

	A	B	C	D
1				
2	Staging			
3	Equipment	Qty	Provided By	Notes
4	Pop-Up	1	name	
5	Table	2	name	
6	Chairs	2	name	
7	Clip Boards	2	name	
8	Signs identifying stations	3	name	
9	T-Cards	25	Trailer	Record assignment of participants to Teams
10	HTs	1 each	All Staff	Maintain contact on Command Net
11				
12				
13	Location 1 -Evaluators			
14	Equipment	Qty	Provided By	Notes
15	Pop-Up	1	Evaluators	
16	Table	1	Evaluators	
17	Chairs	2	Evaluators	
18	Dual Band Radio for evaluations	1	Evaluators	
19	Clip Boards	2	Evaluators	
20	Sign identifying evaluators	1	Evaluators	
21	Evaluation forms and documents		Evaluators	
22				
23				
24	Location 1			
25	Equipment	Qty	Provided By	Notes
26	list of equipment here	4	name	3 for exercise
27	Traffic Cone	2	name	
28				
29	Location 2			
30	Equipment	Qty	Provided By	Notes
31	Pop-Up	1	name	
32	Table	1	name	
33	Chairs	2	name	

Copyright 2024 Santa Clara County ARES®/RACES. All rights reserved.

SAFETY PLANNING

- Prepare Safety Briefing to be included in participant packet at Staging
- Obtain or verify supplies
 - Caution Tape and Flagging Tape
 - Traffic Cones
 - First Aid Kit
 - Fire Extinguisher for each generator within 25'
 - Pan under generator needed to catch fuel/oil spills
 - Map of venue showing key locations
- Identify Safety Issues and mark
 - Trip hazards – cones at end of tripod legs and end of guy lines/ropes
 - Overhead and eye level obstructions – tie caution tape flags
 - RF fields – RF exposure evaluation – FCC Form 610
 - Power distribution/electrocution
- Contact for 911, local phone numbers for Fire & PD



SAFETY PLANNING

- Other Site Issues
 - Vehicles / Trailers: Wheels chocked
 - Storage bins/supplies: Keep out of public walkways
 - Maintain clear walkways for public
 - Antennas away from power lines
- Personal Safety – *Make part of safety briefing*
 - Stay hydrated (Note: Coffee is not a substitute for water)
 - Use sun protection
 - Weather related issues - hypothermia, heat exhaustion, etc.
 - Participants wearing specified Safety Vests
 - Is other safety gear needed--how to obtain, issue, track
 - Report any unsafe condition or activity to IC or Safety Officer
 - Document procedures for reporting a real emergency



STAGING PLANNING

- Documentation
 - DSW List
 - Event Sign-up/position lists
 - Event planning documents as appropriate from area planners
 - Participant materials (one for each participant including staff)
 - ICS-205
 - Safety Briefing (2 copies, one copy to be signed and returned to Staging)
 - Map of event location/facilities if appropriate
 - Any briefing documents based on scenario ISC-201, ISC-202
- Forms/supplies
 - ICS-211
 - ICS-214 (In case participants forget to bring one)
 - T-Cards (include instruction on how to fill it out)
 - Clipboards & pens
 - File Folders
 - Paper weights
- Equipment
 - Tables and chairs
 - Pop-up or other shelter
 - Radio, antenna, power, headphone, etc. if the staging net will be run from the Staging location
 - Signage to identify Staging Location



PUBLIC INFORMATION OFFICER (PIO) PLANNING

- Documentation
 - Event planning documents as appropriate
- Forms/supplies
 - Brochures (ARRL, County, etc.) to distribute to public
 - Press Kit if appropriate
 - Business Cards
 - ID Badge or other visible identification
 - Clipboard & pen
 - Paper weights
- Equipment
 - Table, chair, pop-up or other shelter if appropriate
 - Radio for demonstration if appropriate
 - Signage to identify location for public information about event



TYPE 1 CREDENTIALS

F1, N1, P1, S1

- In addition to the training and participation requirements:
- Operator skill: Plan, design, and set-up information flow and communications support for an approved county drill, event or incident. Must be approved by Credential Program Manager.
- Give it a try
 - Join the staff for the next county wide communications drill!
 - Take on a planning role with your city

Current Credential Holders



F1	N1	P1	S1
5	6	0	5
F2	N2	P2	S2
17	12	13	9





TABLETOP EXERCISE

THE PLANNING MEETING

- Return to previous team
 - Planning Leader (PL) (Same as previous unless there is a good reason to change)
Recruit and assign planners to each role
 - Area Planners
 - Net Control Planner
 - Packet Planner
 - Field Ops Planner
 - Shadow Planner
 - Logistics Planner (Assign if only enough people are on your team to staff this position)
 - Staging Planner (Assign if only enough people are on your team to staff this position)
 - Safety Planner (Assign if only enough people are on your team to staff this position)
 - PIO Planner (Assign if only enough people are on your team to staff this position)
- ALL: Use handout - Drill Planning Task Checklists
- PL: Review ICS-202 Incident Objectives with the planning team (<5 Minutes) 
- Area Planners: coordinate plans with other planners (overview only)
- **Area Planners: (15 minutes) Create a quick overview for your planning area to include staff and equipment needs and summarize your initial thoughts. Ask questions of other planners as needed.**
- PL: Complete an ICS-201 as if you were preparing for a participant briefing
- PL: Answer questions and provide guidance to your planning team
- The Instructor will be your simulated 'Served Agency Representative' for any questions 
- **PL: Conduct a planning meeting to share ideas/plans with the planning team and discuss. Rework ideas/plans based on meeting.**
- PL: Be prepared to summarize and explain the teams plans

GROUP BREAKOUT DISCUSSION

ANSWER THE FOLLOWING

1. What type and quantity of staff do you need? Explain your reasoning.
2. How many and what type of nets do you need?
3. What are your equipment considerations/needs?
4. How will you send medical requests?
5. How will you send dropped out runner information?
6. What safety concerns were raised?
7. What other major issues/concerns were noted?
8. Other comments, thoughts, or questions?



AFTER ACTION REPORT - HOMEWORK

Create an After-Action Report for your exercise

Base your AAR on the plans you created today. Think about how this type of event may unfold and if your plans cover all aspects of what could happen at the event. If you think the plans are lacking then note that.

- Your AAR is for your planning area only, not the entire event.
- Use the AAR template provided.
- Complete all fields as if this event actually happened.
- Include all relevant fields
 - Description of exercise and its goals and objectives (on ICS-202)
 - Results achieved
 - Problems and concerns
 - Observations and feedback
 - Lessons learned
 - Improvement ideas for future classes/tabletop exercises
- Like all documents - Make it Legible – someone else needs to read it.

IN SUMMARY

- **Keep your goals and objectives measurable and attainable in the allotted time.**
- **Don't over complicate your planning.**
- **The best laid plans can go sideways in an instant.**
- **Nothing ever goes as planned.**
- **You will have challenges that you need to address on the fly**
- **Gather feedback at the end of an exercise or incident.**
- **Make sure you do an AAR. **Required for County Mutual Aid Events.****
- **Make the corrections and improvements as soon as possible.**
- **Your follow-on exercise should proof your changes and improvements and build on the skill levels of your participants.**
- **Be open to ALL creative solutions and resources (staffing and equipment) that present themselves.**

THE PLANNING 'P'

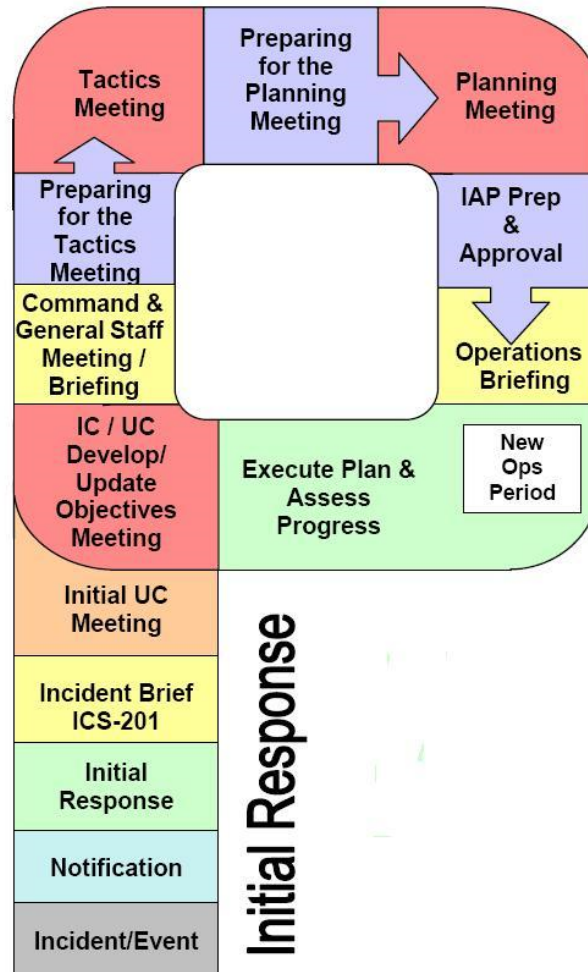

REVIEW LEARNING OBJECTIVES

- At the end of this course, students will be able to:
 - Describe the different types of events
 - Create measurable exercise objectives
 - Describe the planning process and what is different based on the event type
 - Describe how to deal with problems that might be encountered during the planning process
 - Properly complete an ICS-202 Incident Objectives form
 - Explain how to use check lists as a planning aid
 - Create an event plan for a functional area of a drill or public service event
 - Create an After Action Report (AAR)

QUESTIONS



THANK YOU!

Please email your **After-Action Report** to instructor within 7 days. Use Subject: AAR Planning Class 2024

If you have questions or feedback about this or other training activities, you can join our Training discussion group.

<https://scc-ares-races.groups.io/g/training>

This is a moderated group.

If you would like to help plan the next County Wide Drill contact me: ke6tim@arrl.net

Final Assignment

Please complete the course evaluation within one-week.

To get course credit you need to:

- A) Attend at least 90% of the class
- B) Participate in class tabletop discussion and planning
- C) Complete and turn in the After-Action Report
- D) Complete the on-line class evaluation

If you do these, you will get credit for the course.

Online Class Evaluation

Log Into: <https://www.scc-ares-races.org/activities/events.php>
Under the EVENTS Menu click on “Submit Class Evaluation”

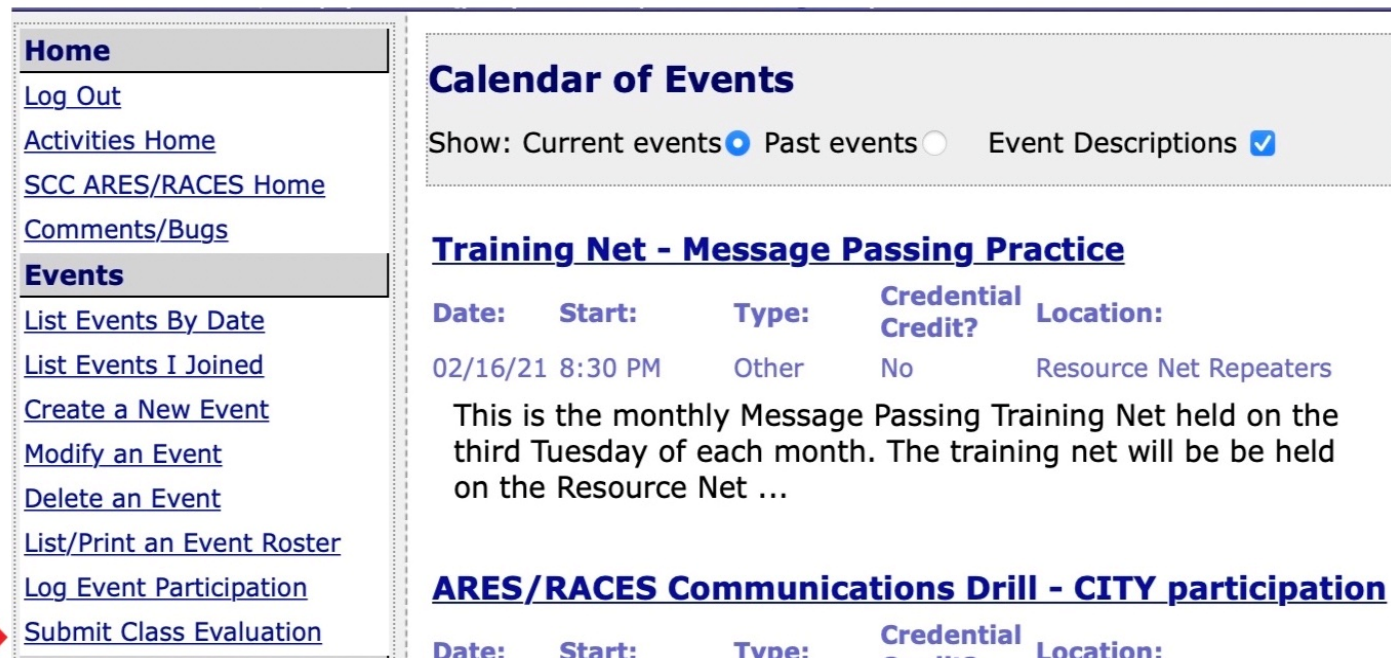

The screenshot shows the website's navigation menu on the left and the main content area on the right. The menu includes links for Home, Log Out, Activities Home, SCC ARES/RACES Home, Comments/Bugs, and an Events section. The Events section contains links for List Events By Date, List Events I Joined, Create a New Event, Modify an Event, Delete an Event, List/Print an Event Roster, Log Event Participation, and Submit Class Evaluation. A large red arrow points to the 'Submit Class Evaluation' link. The main content area features a 'Calendar of Events' section with filters for 'Current events' (selected), 'Past events', and 'Event Descriptions'. Below this is a table listing an event titled 'Training Net - Message Passing Practice' with details for date, start time, type, credential credit, and location. A description follows, stating it is a monthly training net held on the third Tuesday of each month. Another event title, 'ARES/RACES Communications Drill - CITY participation', is partially visible at the bottom.

Home

[Log Out](#)

[Activities Home](#)

[SCC ARES/RACES Home](#)

[Comments/Bugs](#)

Events

[List Events By Date](#)

[List Events I Joined](#)

[Create a New Event](#)

[Modify an Event](#)

[Delete an Event](#)

[List/Print an Event Roster](#)

[Log Event Participation](#)

[Submit Class Evaluation](#)

Calendar of Events

Show: Current events Past events Event Descriptions

Training Net - Message Passing Practice

Date:	Start:	Type:	Credential Credit?	Location:
02/16/21	8:30 PM	Other	No	Resource Net Repeaters

This is the monthly Message Passing Training Net held on the third Tuesday of each month. The training net will be held on the Resource Net ...

ARES/RACES Communications Drill - CITY participation

Date:	Start:	Type:	Credential Credit?	Location:
-------	--------	-------	--------------------	-----------